

LT tank horizontal 1200 L

Description:

This vessel is designed for final fermentation, storage and racking of beer.

Accessories:

Oval manhole 340*420 mm	1.4301
Sanitary shower DN 25 with piping DN 25 mm	1.4301
Level indicator DN 15	1.4301
Underpressure/overpressure armature DN 20	1.4301
Supply and discharge flap valve DN 32	1.4301
Upstream armature DN 32	1.4301
Blind flange DN 32, 1 piece	1.4301

Operating conditions:

Maximum operating temperature	80°C
Minimum operating temperature	-15°C

Parameters

Overall height	1 115 mm
Diameter	990 mm
Overall capacity	1 338 l
cylindrical part	1 154 l
ached bottom	92 l
Empty weight	136 kg
Length	2 200 mm

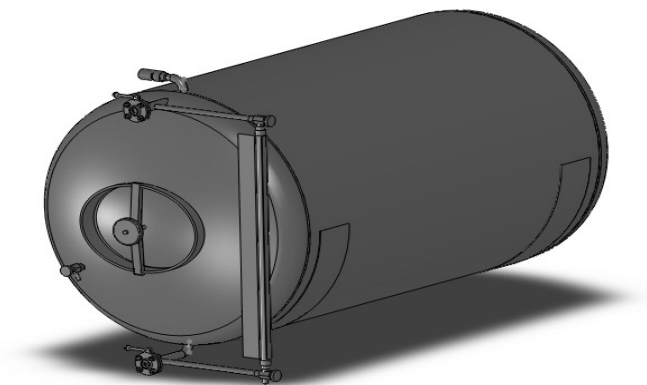

Warranty:

PT tank	36 months
Upstream armature	36 months

Transport

This tank is usually shipped in horizontal position, fixed on special framing.
Ground-plan frame dimensions: 2000x900 mm

DOUBLE-ACTING VALVE DVZ1

1. UTILISATION

This double-acting valve is intended for utilisation in equipment and spaces working with operating overpressure in order to prevent them against exceeding its permissible limits. Such equipment shall be protected also against possible implosion provided its operating medium is pumped out because it allows air suction inwards.

2. ASSEMBLY

This double-acting valve can be installed in any position, however, it is mounted usually in a vertical position on a vessel top part, screwed in its threaded counterpart on the vessel, under use of proper thread type seal, usually with Teflon packing strips.

1. Body
2. Tube
3. Plate
4. Underpressure plate
5. Food seal EPDM
6. Bolt M6
7. Nut M6
8. Overpressure spring
9. Underpressure spring
10. Adjusting bolt
11. Locking washer

